

5 TON HORIZONTAL AIR CONDITIONER



The KPO5-43 is a horizontal 5-ton portable air conditioning system rated at 60,000 BTU for construction, industrial & commercial applications. At only 32" wide it fits through most single-man doors — ideal where space is limited.

Product Features

- Horizontal chassis fits through standard single-man doors
- 460V / 3-phase power with Camlock connections
- Internal condensate pump
- Forklift pockets & heavy-duty casters
- VFD on condenser fan (3,500 CFM)
- CSA certified — Canada & US

TECHNICAL SPECS	
Unit Model	KPO5-43
BTU / Hr Input	60,000 (5 Ton)
Voltage / Phase	460V / 3
Cooling Amps	14 A (20 A Circuit)
Connections	Camlock Male
Evap Air Flow	2,400 CFM
Supply Outlet	(1) 12" Round (50' Max)
Return Inlet	(1) 12" Round (50' Max)
Cond Air Flow	3,500 CFM w/ VFD
Cond Outlet	(1) 12" Round (65' Max)
Weight	710 lbs
Dimensions (L×W×H)	48" × 32" × 49"
Forklift / Casters	Yes / Yes
Condensate Pump	Yes (Internal)
Certifications	CSA Canada & US

Unit Drawings

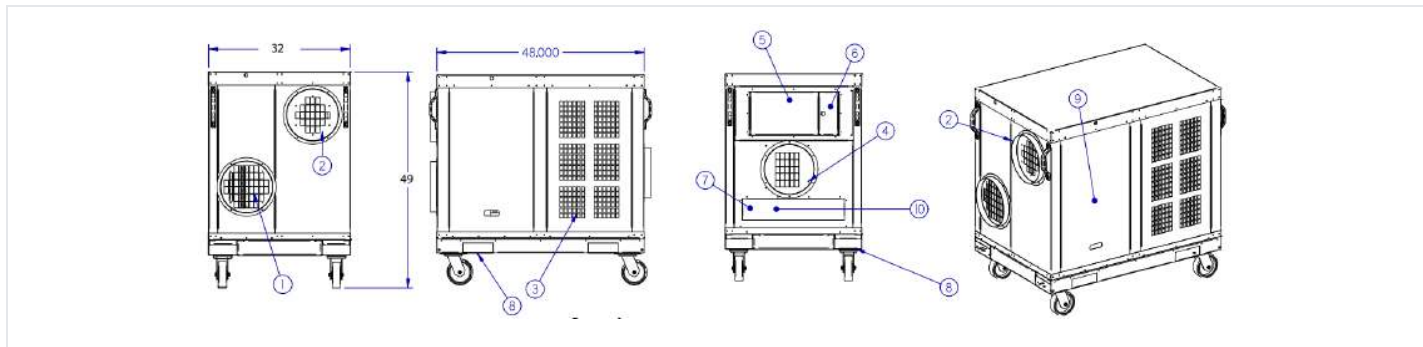

- | | | | | |
|-------------------------|----------------------|------------------------|-------------------------|---------------------|
| 1. Cold Air Return | 2. Cold Air Supply | 3. Condenser Air Inlet | 4. Condenser Air Outlet | 5. Electrical Panel |
| 6. Control Panel Access | 7. Condensate Nipple | 8. Fork Pocket | 9. Access Door | 10. Power Cord |