

# DF2300 MAKE-UP AIR HEATER



By drawing 100% fresh air, Make-Up Air Heaters reduce air contaminants & pollutants while managing humidity levels and preventing condensation & mold growth. The thermostatically controlled air also prevents negative pressure that can lead to drafts and outside-air infiltration. The DF2300 is equipped with wide-scope gas modulation valving allowing for maximum temperature control and significant fuel savings. Like a permanent air handler, the DF2300 provides evenly distributed, warm, dry air.

TECHNICAL SPECS	
BTU / Hr Input	320,000 – 2,300,000
Voltage	230V
Phase	3
Circuit Size	30 A @ 230V
Fuel	LP / NG
Air Delivery	15,000 CFM
Air Outlet	27" x 23" (or equivalent)
Weight	1,900 lbs
Dimensions (L x W x H)	98" x 48" x 54"
Gas Modulation	Yes
Forklift Pockets	Yes
Lifting Eyes	Yes
Casters	Yes

## Product Features

- Enclosed flame
- Wide-scope gas modulation valving — maximum temperature control and significant fuel savings
- Draws 100% fresh air — manages humidity, prevents condensation & mold growth
- Thermostatically controlled — prevents negative pressure, drafts & outside-air infiltration
- Forklift pockets, lifting eyes & casters

## Unit Drawings

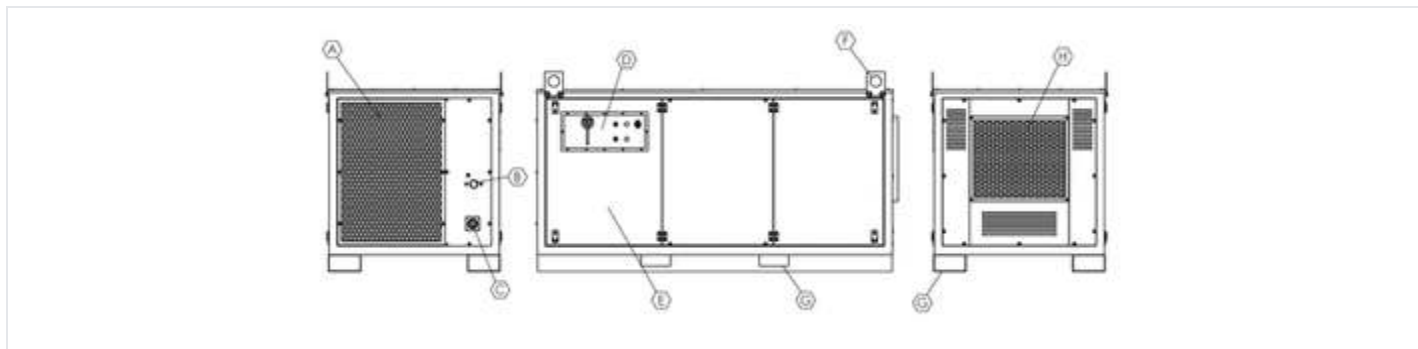

- |                               |                            |                                 |                         |
|-------------------------------|----------------------------|---------------------------------|-------------------------|
| <b>A.</b> Inlet Screen        | <b>B.</b> 1-1/2" Gas Inlet | <b>C.</b> Electrical Connection | <b>D.</b> Control Panel |
| <b>E.</b> Service Access Door | <b>F.</b> Lifting Eyes     | <b>G.</b> Fork Pockets          | <b>H.</b> Air Discharge |