

FHL1100 MAKE-UP AIR HEATER



By drawing 100% fresh air, Make-Up Air Heaters reduce air contaminants & pollutants while managing humidity levels and preventing condensation & mold growth. The thermostatically controlled air also prevents negative pressure that can lead to drafts and outside-air infiltration. The FHL1100's burner alternates between high-fire and low-fire for precise temperature control. This versatile heater can be situated on the exterior like a permanent air handler, on the interior drawing make-up air, or set up as a ductless recirculating heater.

Product Features

- Enclosed flame
- High-fire / low-fire burner for precise temperature control
- Lifting eyes & casters

Unit Drawings

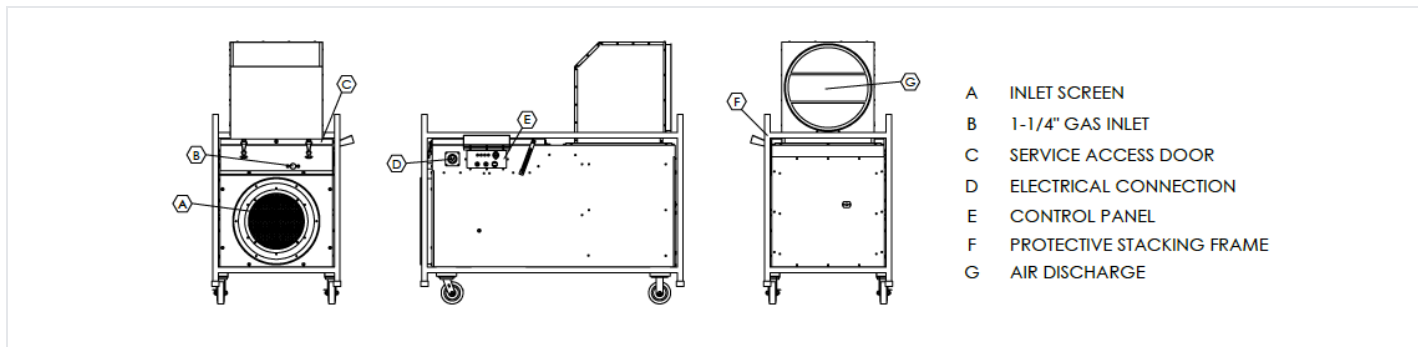

TECHNICAL SPECS	
BTU / Hr Input (High-Fire)	1,100,000
BTU / Hr Input (Low-Fire)	405,000
Voltage	230V
Phase	1
Circuit Size	15 A @ 230V
Fuel	LP / NG
Air Delivery	8,300 CFM
Air Inlet / Outlet	24" Round / 24" Round
Weight	715 lbs
Dimensions (L x W x H)	71.5" x 35" x 72"
Forklift Pockets	No
Lifting Eyes	Yes
Casters	Yes