

HR500 MAKE-UP AIR HEATER



| TECHNICAL SPECS | |
|-------------------------------------|-----------------------|
| BTU / Hr — High-Fire (LP/NG) | 500,000 |
| BTU / Hr — Low-Fire (LP) | 325,000 |
| BTU / Hr — Low-Fire (NG) | 335,000 |
| Voltage | 120V |
| Phase | 1PH |
| Circuit Size | 20 A |
| Fuel | LP / NG |
| Air Delivery | 4,000 CFM |
| Air Inlet / Outlet | 16" Round / 16" Round |
| Weight | 600 lbs |
| Dimensions (L x W x H) | 62" x 32" x 63" |
| Forklift Pockets | No |
| Lifting Eyes | Yes |
| Casters | Yes |
| Certifications | eETLus |

Product Features

- Draws 100% fresh air — reduces air contaminants & pollutants
- Burner alternates between high-fire and low-fire for precise temperature control
- Thermostatically controlled — prevents negative pressure, drafts & outside-air infiltration
- Exterior, interior make-up air, or ductless recirculating setup
- Manages humidity, prevents condensation & mold growth

Unit Drawings

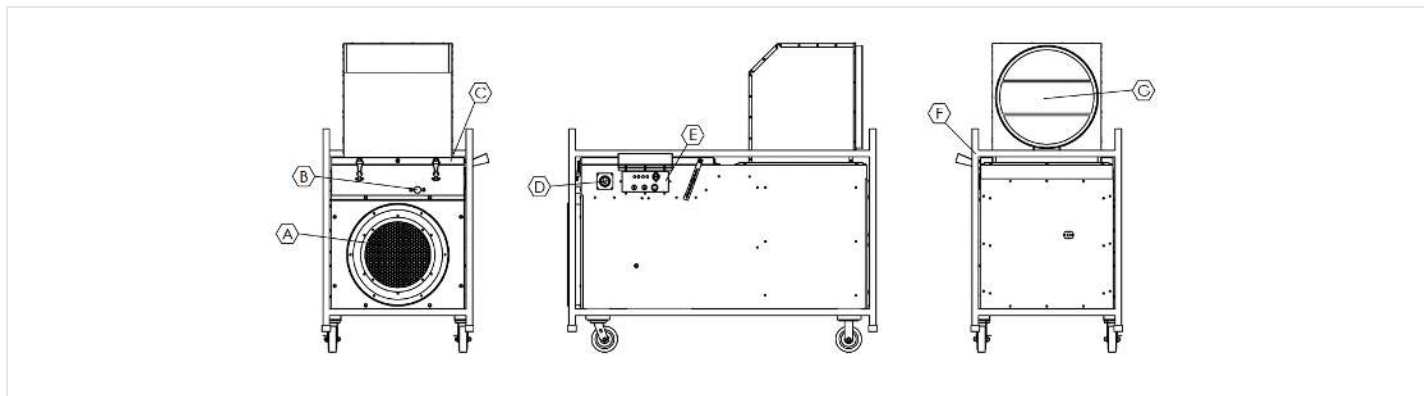

- | | | | |
|------------------------|------------------------------------|------------------------------|--------------------------------|
| A Inlet Screen | B 1-1/4" Gas Inlet | C Service Access Door | D Electrical Connection |
| E Control Panel | F Protective Stacking Frame | G Air Discharge | |